

## DIMENSIONS

All Dimensions are Approximate. Dimensions May Vary with Bucket. Refer to Operating Specifications.

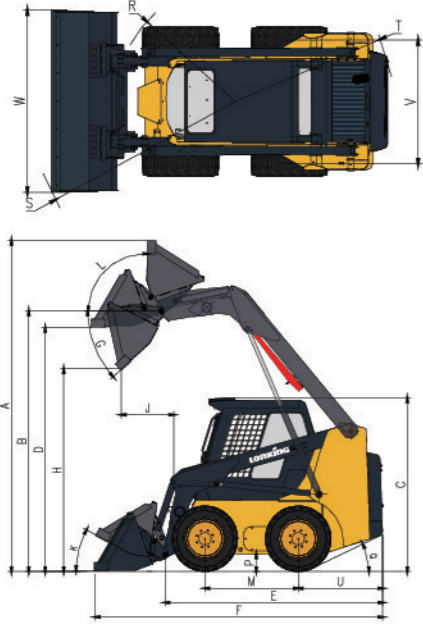

NO.	SPECIFICATION	UNIT	CDM312
A	Max.Operation Height	mm	3880
B	Bucket Pin Height	mm	3060
C	Cab Roof Height	mm	2020
D	Max.Height at Bucket Leveled	mm	2870
E	Length without Attachment	mm	2530
F	Length with Standard Bucket	mm	3460
H	Dumping Height	mm	2440
J	Reach Rollback	mm	610
M	Wheelbase	mm	1080
P	Ground Clearance	mm	180
R	Front Turning Radius without Attachment	mm	1180
S	Front Turning Radius	mm	2050
T	Rear Turning Radius	mm	1580
U	Tail Length	mm	980
V	Center Distance between Two Wheels	mm	1320
W	Bucket Width	mm	1820
G	Dumping Angle at Max.Height	°	40
K	Bucket Angle on Ground	°	29
L	Bucket Rollback Angle at Max.Height	°	96
Q	Start Angle	°	28

MACHINE MODEL	UNIT	CDM312-I	CDM312-II	CDM312-III
<b>MAIN SPECIFICATION</b>				
Engine Model		KUBOTA V3600-T-E3B	XINCHAI A498BZG	KUBOTA V3600-T-E3B
Emission Standard		EuroIIIA	Nation II	EuroIIIA
Rated Power	kW/rpm	63/2600	55/2500	63/2600
Operating Weight	kg	3700	3700	3700
Rated Payload	kg	1230	1230	1230
Bucket Capacity	m³	0.54	0.54	0.54
L×W×H	mm	3460×1820×2020	3460×1820×2020	3460×1820×2020
<b>ENGINE SYSTEM</b>				
Engine Model		KUBOTA V3600-T-E3B	XINCHAI A498BZG	KUBOTA V3600-T-E3B
Rated Power	kW/hp/rpm	63/86/2600	55/75/2500	63/86/2600
Displacement	L	3.62	3.168	3.62
Stroke	mm	98	98	98
Bore	mm	120	105	120
<b>WEIGHTS</b>				
Operating Weight	kg	3700	3700	3700
<b>POWER TRAIN</b>				
Travel Speed -F&R	km/h	11.8	11.8	11.8
<b>TIRE</b>				
Tyre		12×16.5	12×16.5	12×16.5
<b>HYDRAULIC SYSTEM</b>				
Hydraulic Flow – Standard	L/min/rpm	Mechanical Servo 91	Mechanical Servo 91	Pilot Control 91
Loader Hydraulic Pressure	MPa	21	21	21
Hydraulic Flow – High Flow	L/min/rpm	135	135	135
Loader Hydraulic Pressure	MPa	19	19	19
<b>OPERATING SPECIFICATIONS</b>				
Rated Payload	kg	1230	1230	1230
Tipping Load	kN	2460	2460	2460
Breakout Force	kN	25.9	25.9	25.9
Traction Force	kN	28.06	28.06	28.06
<b>SERVICE REFILL CAPACITIES</b>				
Chain Box, Each Side	L	9	9	9
Cooling System	L	12	12	12
Engine Crankcase	L	9	9	9
Fuel Tank	L	91	91	91
Hydraulic Tank	L	65	65	65

# LONKING

Efficiency Rules the Future

## CDM312 SKID STEER LOADER

Famous Engine  
Import Hydraulic System  
Integral Instrument Panel  
AC Cabin  
Worldwide Universal Quick-change Connector  
Various Attachments as Optional



	CDM312-I	CDM312-II	CDM312-III
ENGINE MODEL:	KUBOTA V3600-T-E3B	XINCHAI A498BZG	KUBOTA V3600-T-E3B
RATED POWER(kW/rpm):	63/2600	55/2500	63/2600
OPERATING WEIGHT(kg):	3700	3700	3700
RATED PAYLOAD(kg):	1230	1230	1230
BUCKET CAPACITY(m³):	0.54	0.54	0.54

LONKING (FUJIAN) INTERNATIONAL TRADE CO.,LTD.  
**LONKING HOLDINGS LIMITED**

Add:26 Minyi Road,Xinqiao,Songjiang Industrial Zone,Shanghai  
P.C: 201612

Tel: +86-21-3760 2200-5650

http://www.lonkinggroup.com

E-mail:export@lonking.cn

Lonking, Lonking CDM Series and their respective logos, as well as corporate identity in this wallet are trademarks of Lonking Holdings Ltd. and may not be used without written permission.

2016/02

For more information on Lonking products,  
Please contact our local agent:



Specifications and design are subject to change without prior notice.  
Machines shown may not include optional accessories.